



K

RENAULT TRUCKS

MINING OFFER

K500 R6X4 XTREM 13L E3



**RENAULT
TRUCKS**

www.renault-trucks.com

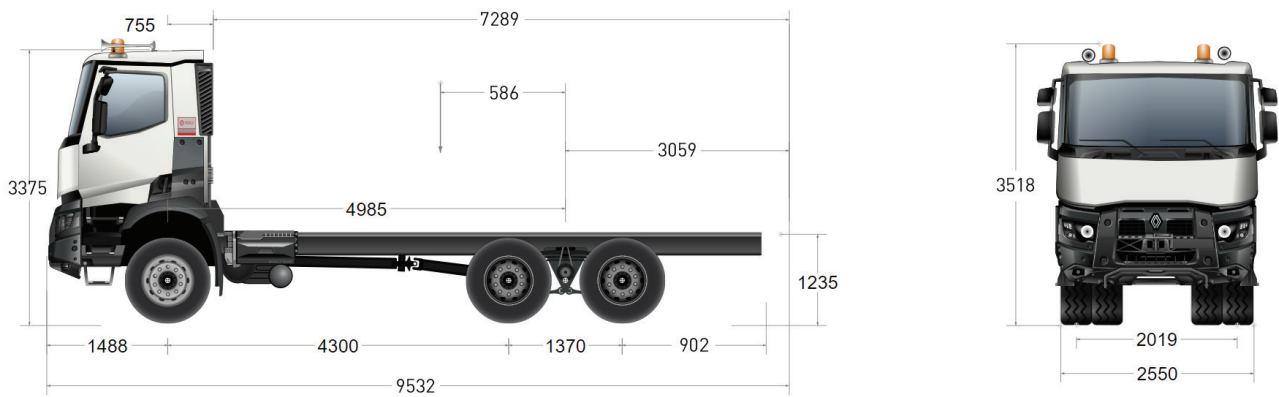

DIMENSIONS

Wheelbase.....	4 300 mm
Overall Chassis Length.....	7 983 mm
Overall height.....	3 518 mm
Overall width.....	2 550 mm
Front Ground clearance.....	430 mm
Rear Ground clearance	395 mm
Overall turning radius	11 500 mm

WEIGHTS

Kerb Weight.....	10 183 kg
Front axle capacity.....	10 000 kg
Rear axles capacity.....	36 000 kg
Gross Vehicle Weight.....	45 000 kg
Available load.....	34 817 kg

ENGINE

Type.....	DXi 13 - 6 cylinders in-line Diesel Engine
Capacity.....	12,8 L
High pressure fuel injection by injector pump	
Max. Power	500 hp - 1 450 to 1 800 rpm
Max. Torque	2400 Nm - 1050 to 1400 rpm
Engine retarder max. power.....	414 kW@2300rpm
Emission standard	Euro III

CLUTCH

Clutch Type.....	Single plate - 430 mm
Clutch actuation	Electro pneumatic

GEARBOX

Type.....	Optidriver AT 2612 XTREM
No. of Gear.....	12 forward + 3 reverse
Gear and clutch actuation.....	fully automated
Mode selection.....	auto/manual from steering wheel
Enhanced software for mining and off-road conditions	
Heavy duty transmission oil cooler	
Power Take-Off.....	PTO S81 Max Torque: 1000 Nm

REAR AXLES

Type	PMR3361R double reduction / ratio 5,41
Cast iron housing designed for mining and off-road	
Integral differential lock	

FUEL TANK

Type.....	Main steel tank / 380 L
-----------	-------------------------

WHEELS AND TYRES

Dimension.....	325/95 R24
----------------	------------

SUSPENSION

Front.....	4-leaf reinforced parabolic, maintenance-free
Rear.....	4-leaf reinforced parabolic

BRAKES AND SAFETY

Drum brakes	
Electronic Brakes System (EBS)	
Electronic Air production management (EACU)	
Electronic parking brake (EPB)	
Reinforced parking brake for mining and off-road	
Coupling of retarders and Services brakes	
Braking with 2 independent circuits	
ABS Braking system with Off Road mode	
Hill Start Aid (HSA)	
Emergency braking assist (AFU)	
Brake performance warning	

ELECTRICAL EQUIPMENT

Battery capacity	185 Ah
Alternator	110 A
LED rear signaling/lighting (EEC standard e2 10113)	
Reversing warning: buzzer and hazard warning lights	

CAB INTERIORS

Air conditioning, air filtration with washable filter	
Pneumatic suspended and adjustable driver seat	
Digital display for essential driving information	
Automatic engine shutdown.	

EXTERIORS

Day cab, 4 points mechanical suspension	
Steel cab, electro-zinc plated & cataphoretic treatment	
Steel bumper – approach angle 32°	
Front towing device 32 T capacity	
2 wide angle rearview mirror (kerb view)	
Tinted, Laminated windscreen.	
2 rotating orange LED lights	
Twin air horns – roof mounted	

TELEMATICS

Optifleet 3 years prepaid subscription	
CHECK : fuel & driver performance monitoring	
MAP+ : geolocation, geofencing and route analysis	

3 YEARS WARRANTY

1st year full/ unlimited mileage.	
2 nd and 3 rd year: driveline (max 450 000km)	