



**K**

**RENAULT TRUCKS**

MINING OFFER

**K500 R8X4 XTREM 13L E3**



**RENAULT  
TRUCKS**

[www.renault-trucks.com](http://www.renault-trucks.com)

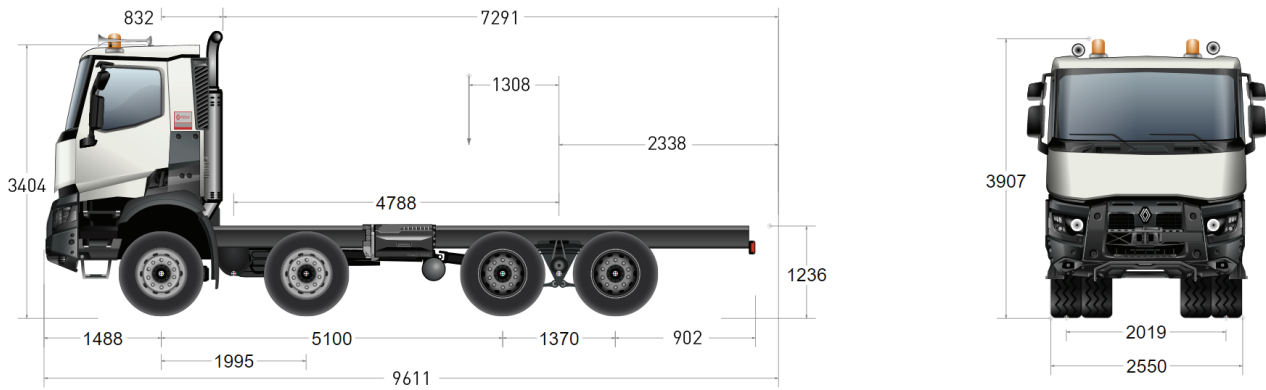

**DIMENSIONS**

Wheelbase..... 5 100 mm  
 Overall Chassis Length..... 8 783 mm  
 Overall height.....3908 mm  
 Overall width.....2 550 mm  
 Front Ground clearance.....430 mm  
 Rear Ground clearance .....395 mm  
 Kerb to Kerb turning radius .....12 661 mm

**WEIGHTS**

Kerb Weight.....11 567 kg  
 Front axle capacity.....20 000 kg  
 Rear axles capacity .....36 000 kg  
 Gross Vehicle Weight.....56 000 kg  
 Available load.....44 433 kg

**ENGINE**

DXi 13 - 6 cylinders in-line Diesel Engine  
 Capacity.....12,8 L  
 High pressure fuel injection by injector pump  
 Max. Power.....500 hp - 1450 to 1 800 rpm  
 Max. Torque .....2400 Nm - 1050 to 1400 rpm  
 Engine retarder max. power..... 414 kW @2300rpm  
 Emission standard ..... Euro III

**CLUTCH**

Clutch Type.....Single plate - 430 mm  
 Clutch actuation.....Electro pneumatic

**GEARBOX**

Type..... Optidriver AT 2612 XTREM  
 No. of Gear.....12 forward + 3 reverse  
 Gear and clutch actuation.....fully automated  
 Mode selection.....auto/manual from steering wheel  
 Enhanced software for mining and off-road conditions  
 Heavy duty transmission oil cooler  
 Power Take-Off.....PTO S81 Max Torque: 1000 Nm

**REAR AXLES**

Type .....PMR3361R double reduction / ratio 5,41  
 Cast iron housing designed for mining and off-road  
 Integral differential lock

**FUEL TANK**

Type.....Main steel tank/380 L

**WHEELS AND TYRES**

Dimension..... 325/95 R24

**SUSPENSION**

Front.....4-leaf reinforced parabolic, maintenance-free  
 Rear.....4-leaf reinforced parabolic

**BRAKES AND SAFETY**

Drum brakes  
 Electronic Brakes System (EBS)  
 Electronic Air production management (EACU)  
 Electronic parking brake (EPB)  
 Reinforced parking brake for mining and off-road  
 Coupling of retarders and Services brakes  
 Braking with 2 independents circuits  
 ABS Braking system with Off Road mode  
 Hill Start Aid (HSA)  
 Emergency braking assist (AFU)  
 Brake performance warning

**ELECTRICAL EQUIPMENT**

Battery capacity .....185 Ah  
 Alternator .....110 A  
 LED rear signaling/lighting (EEC standard e2 10113)

**CAB INTERIORS**

Air conditioning, air filtration with washable filter  
 Pneumatic suspended and adjustable driver seat  
 Digital display for essential driving information  
 Automatic engine shutdown

**EXTERIORS**

Day cab, 4 points mechanical suspension  
 Steel cab, electro-zinc plated & cataphoretic treatment  
 Steel bumper – approach angle 32°  
 Front towing device 32 T capacity  
 2 wide angle rearview mirror (kerb view)  
 Tinted, Laminated windscreen  
 2 rotating orange LED lights  
 Twin air horns – roof mounted

**TELEMATICS**

Optifleet: 3 years prepaid subscription  
 CHECK: fuel & driver performance monitoring  
 MAP+: geolocation, geofencing and route analysis

**3 YEARS WARRANTY**

1st year full/unlimited mileage.  
 2<sup>nd</sup> and 3<sup>rd</sup> year: driveline (max 450 000km)