



**CK** **RENAULT TRUCKS**  
FUEL AND LOGISTICS  
**CK420 T6X4 OFF ROAD**



**RENAULT  
TRUCKS**

[www.renault-trucks.com](http://www.renault-trucks.com)

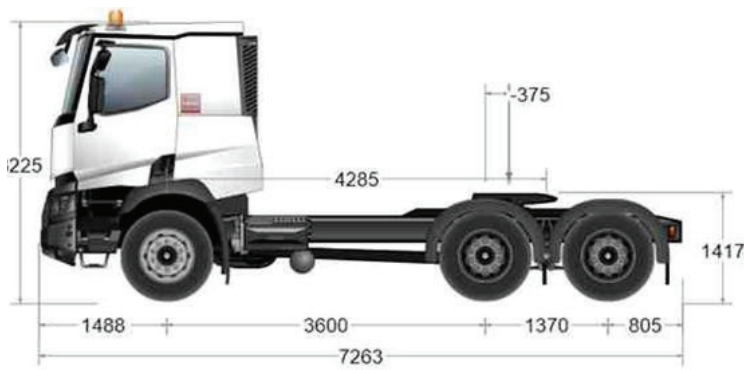

### DIMENSIONS

Wheelbase.....	3 600 mm
Overall Chassis Length.....	7 263 mm
Overall height.....	3 368 mm
Overall width.....	2 507 mm
Front Ground clearance.....	311 mm
Rear Ground clearance .....	346 mm
Overall turning radius.....	8 750 mm

### WEIGHTS

Kerb Weight.....	9 790 kg
Front axle capacity.....	8 000 kg
Rear axle capacity .....	26 000 kg
Gross Vehicle Weight.....	Up to 80 000 kg

### ENGINE

DXi 13 - 6 cylinders in-line Diesel Engine	
Capacity.....	12,8 L
High pressure fuel injection by injector pump	
Max. Power.....	420 hp - 1450 to 1 800 rpm
Max. Torque .....	2200 Nm - 1050 to 1400 rpm
Engine retarder max. power.....	414 kW @2300 rpm
Emission standard.....	Euro III

### CLUTCH

Clutch Type.....	Single plate - 430 mm
Clutch actuation.....	Electro pneumatic

### GEARBOX

Type.....	Optidriver AT 2612
No. of Gear.....	12 forward + 3 reverse
Gear and clutch actuation.....	fully automated
Mode selection.....	auto/manual from steering wheel
Heavy duty transmission oil cooler	

### REAR AXLES

Type.....	PMR2661 double reduction / ratio 3,61
Integral differential lock	

### FUEL TANK

Type.....	Main steel tank/380 L
Capacity.....	380L on right & 350L on left side

### WHEELS AND TYRES

Dimension.....	13R22.5
----------------	---------

### SUSPENSION

Front.....	2-leaf reinforced front leaf springs
Rear.....	3-leaf elliptic suspension

### ADR COMPLIANCY

2 batteries cut out (Cab & chassis)
Driver side exhaust
One foldaway wheel shock - bracket mounted on chassis

### BRAKES

Disk brakes
Electronic Brakes System (EBS)
Electronic Air production management (EACU)
Electronic Parking Brake (EPB)
Coupling of retarders and service brake

### SAFETY & ADR

Hill Start Aid (HSA)
Anti Spin Regulation (ASR)
Forced parking brake if driver's door is open
Braking with 2 independents circuits
ABS Braking system
Emergency braking assist (AFU)
Brake performance warning

### FIFTH WHEEL

Jost 38C, 3.5" cast iron fifth wheel, D 260 kN
--

### ELECTRICAL EQUIPMENT

Battery capacity.....	185 Ah
Alternator.....	110 A
LED rear signaling/lighting	
Reversing warning: buzzer	

### CAB INTERIOR

Air conditioning, air filtration with washable filter
Pneumatic suspended and adjustable driver seat
Digital display for essential driving information

### EXTERIOR

Night & Day cab, 4 points mechanical suspension
1 Single Bunk
Steel cab, electro-zinc plated & cataphoretic treatment
Front towing device 32 T capacity
2 wide angle rearview mirror (kerb view)
Tinted, Laminated windscreen
2 rotating orange LED lights

### TELEMATICS

Optifleet: 3 years prepaid subscription
CHECK: fuel & driver performance monitoring
MAP+: geolocation, geofencing and route analysis

### 3 YEARS WARRANTY

1st year full/unlimited mileage.
2 <sup>nd</sup> and 3 <sup>rd</sup> year: driveline (max 450 000km)